

General Description

It combines advanced trench MOSFET technology with a low resistance package to provide extremely low $R_{DS(ON)}$.

Features

- Advance high cell density Trench technology
- Low $R_{DS(ON)}$ to minimize conductive loss
- Low Gate Charge for fast switching
- Low Thermal resistance

Application

- MB/VGA Vcore
- SMPS 2nd Synchronous Rectifier
- POL application
- BLDC Motor driver

Product Summary

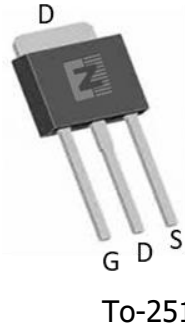
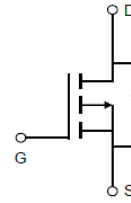
 $V_{DS} = -60V$
 $R_{DS(ON)} = 42m\Omega$
 $I_D = -16A$

Ordering Information:

Part NO.	ZM420P06I
Marking	ZM420P06
Packing Information	Bulk Tube
Basic ordering unit (pcs)	3600

Absolute Maximum Ratings ($T_c = 25^\circ C$)

Parameter	Symbol	Rating	Unit
Drain-Source Voltage	V_{DS}	-60	V
Gate-Source Voltage	V_{GS}	± 25	V
Continuous Drain Current	$I_{D@TC=25^\circ C}$	-16	A
	$I_{D@TC=75^\circ C}$	-12	A
	$I_{D@TC=100^\circ C}$	-10	A
Pulsed Drain Current ^①	I_{DM}	-48	A
Total Power Dissipation ^②	$P_D@TC=25^\circ C$	50	W
Total Power Dissipation	$P_D@TA=25^\circ C$	1.25	W
Operating Junction Temperature	T_J	-55 to 150	$^\circ C$
Storage Temperature	T_{STG}	-55 to 150	$^\circ C$
Single Pulse Avalanche Energy	E_{AS}	45	mJ

•Thermal resistance

Parameter	Symbol	Min.	Typ.	Max.	Unit
Thermal resistance, junction - case ^②	R _{thJC}	-	-	2.4	° C/W
Thermal resistance, junction - ambient	R _{thJA}	-	-	65	° C/W
Soldering temperature, wavesoldering for 10s	T _{sold}	-	-	265	° C

•Electronic Characteristics

Parameter	Symbol	Condition	Min.	Typ	Max.	Unit
Drain-Source Breakdown Voltage	BV _{DSS}	V _{GS} =0V, I _D =-250uA	-60			V
Gate Threshold Voltage	V _{GS(TH)}	V _{GS} =V _{DS} , I _D =-250uA	-1.2		-2.5	V
Drain-Source Leakage Current	I _{DSS}	V _{DS} =-60V, V _{GS} =0V			-1.0	uA
Gate- Source Leakage Current	I _{GSS}	V _{GS} =±20V, V _{DS} =0V			±100	nA
Static Drain-source On Resistance	R _{DS(ON)}	V _{GS} =-10V, I _D =-5A		42	50	mΩ
		V _{GS} =-4.5V, I _D =-3A		65	75	mΩ
Forward Transconductance	g _{FS}	V _{DS} =-10V, I _D =-5A		9		s
Source-drain voltage	V _{SD}	I _S =-5A			1.28	V

•Electronic Characteristics

Parameter	Symbol	Condition	Min.	Typ	Max.	Unit
Input capacitance	C _{iss}	V _{GS} =0V, V _{DS} =-25V f = 1MHz	-	2090	-	pF
Output capacitance	C _{oss}		-	127	-	
Reverse transfer capacitance	C _{rss}		-	93	-	

•Gate Charge characteristics(T_a = 25°C)

Parameter	Symbol	Condition	Min.	Typ	Max.	Unit
Total gate charge	Q _g	V _{DD} =25V I _D = 4A V _{GS} = 10V	-	34	-	nC
Gate - Source charge	Q _{gs}		-	4.6	-	
Gate - Drain charge	Q _{gd}		-	5.9	-	

Note: ① Pulse Test : Pulse width ≤ 300μs, Duty cycle ≤ 2% ;

② Device mounted on FR-4 substrate PC board, 2oz copper, with thermal bias to bottom layer 1inch square copper plate;

Fig.1 Gate-Charge Characteristics

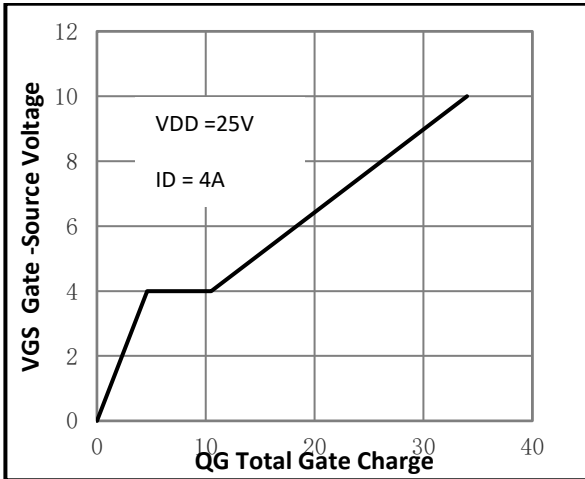

Fig.2 Capacitance Characteristics

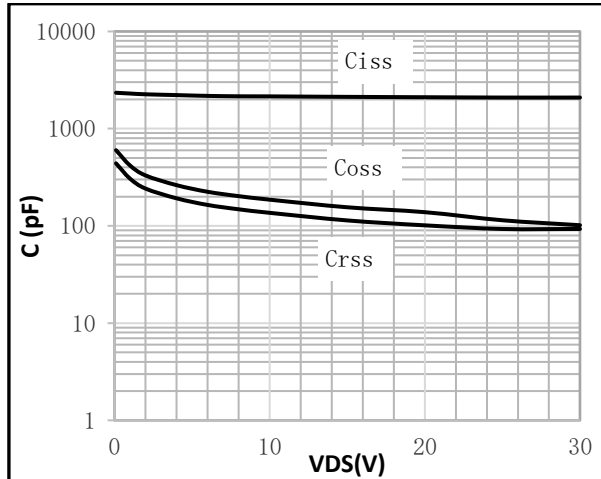

Fig.3 Power Dissipation Derating Curve

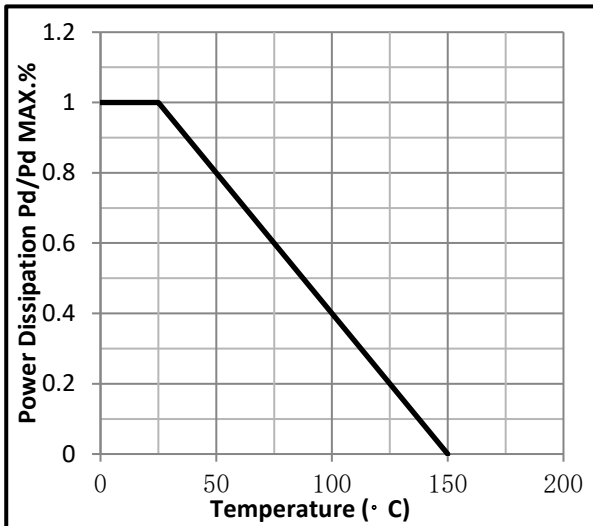

Fig.4 Typical output Characteristics

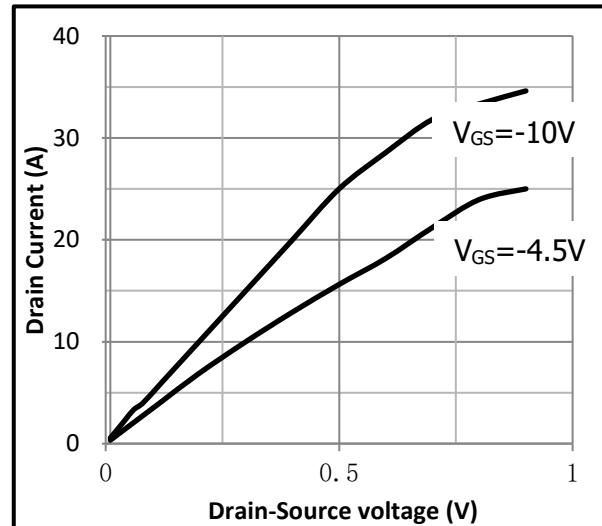

Fig.5 Threshold Voltage V.S Junction Temperature

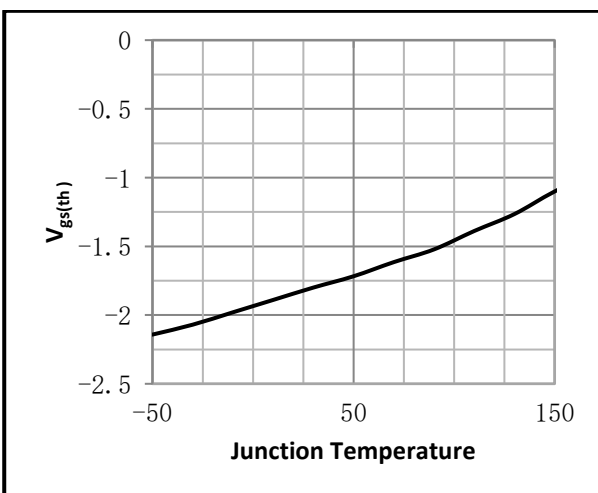

Fig.6 Resistance V.S Drain Current

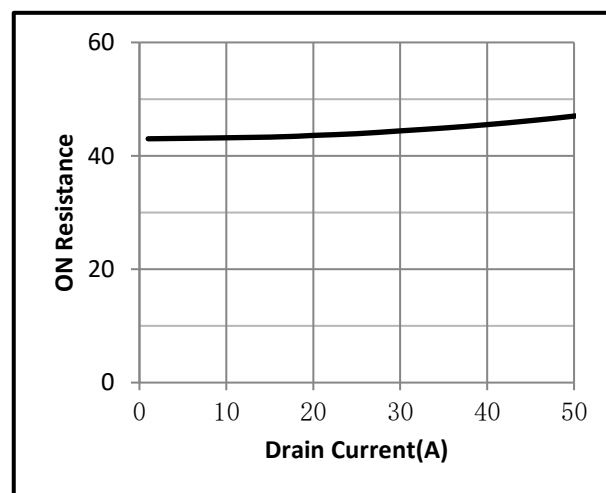

Fig.7 On-Resistance VS Gate Source Voltage

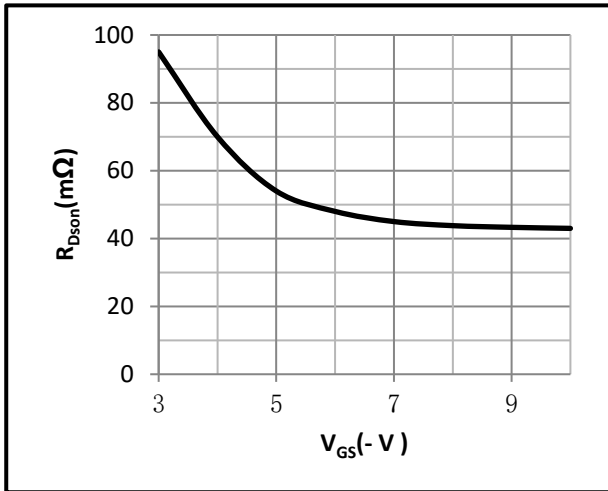

Fig.8 On-Resistance V.S Junction Temperature

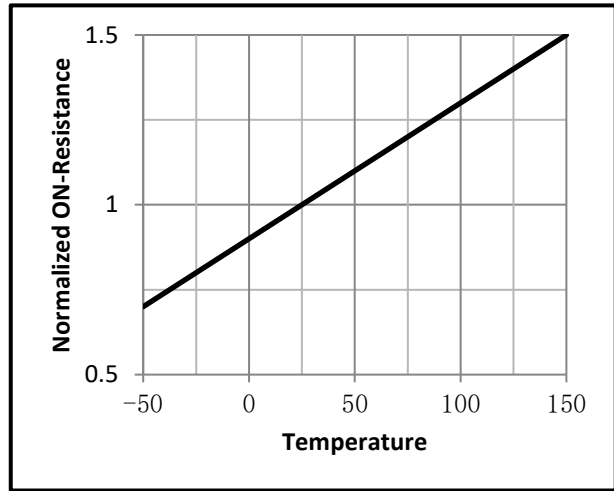

Fig.9 Gate Charge Measurement Circuit

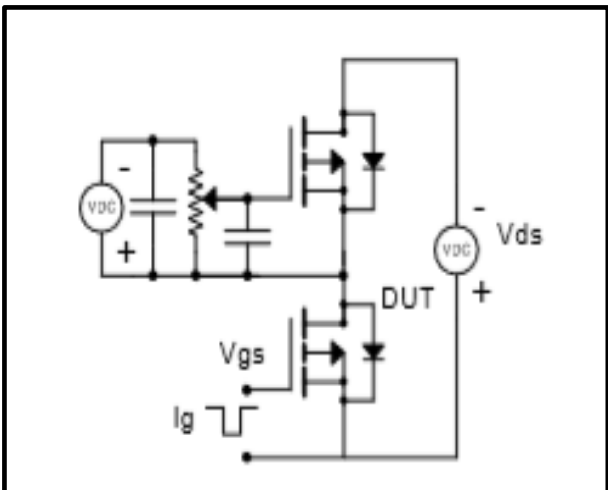

Fig.10 Gate Charge Waveform

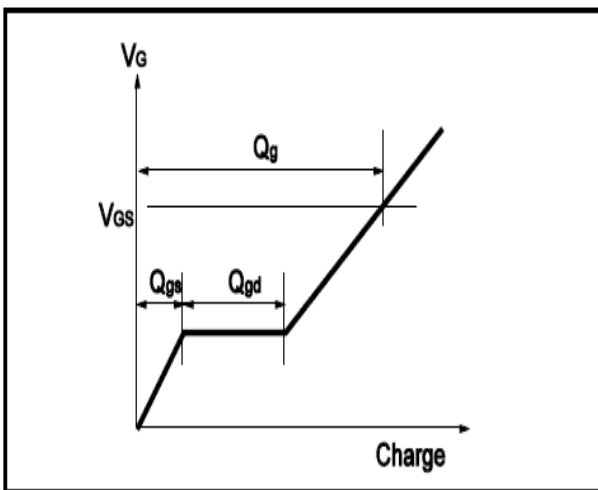

Fig.11 Switching Time Measurement Circuit

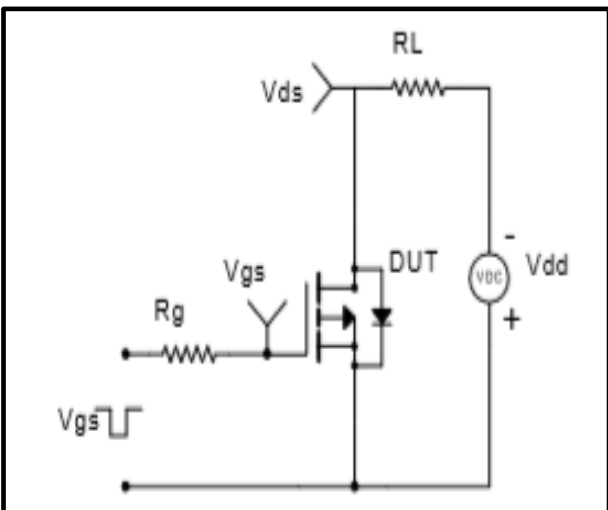
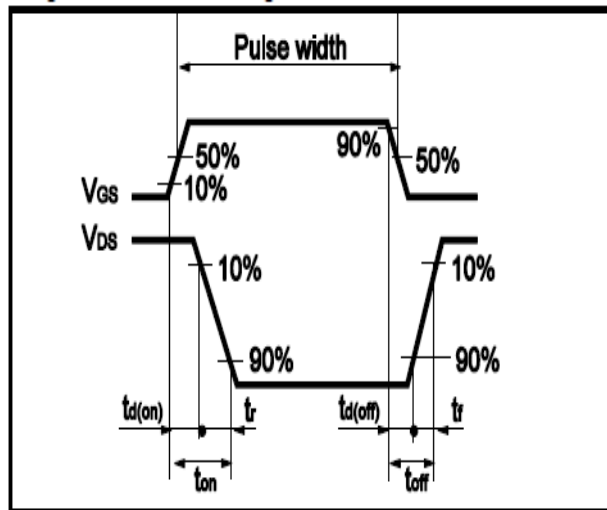

Fig.12 Switching Time Waveform





•Dimensions(TO-251)

Unit: mm

SYMBOL	min	max	SYMBOL	min	max
A	2.10	2.50	D	6.35	6.80
A1	0.95	1.30	D1	5.10	5.50
B	0.80	1.25	E	5.30	6.30
b	0.50	0.80	e	2.24	2.35
b1	0.70	0.90	E1	4.43	4.73
c	0.45	0.60	L	7.00	9.40
c1	0.45	0.60			

